

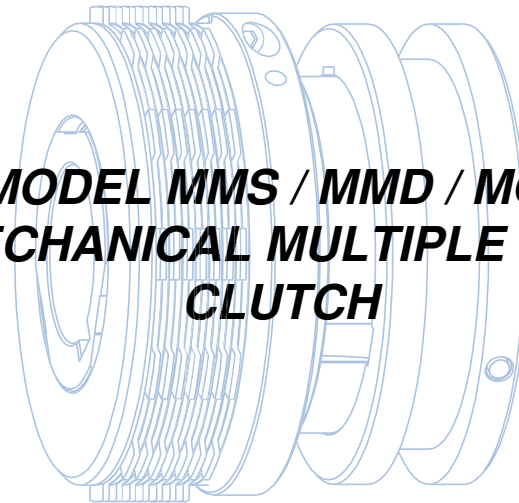

CARLYLE JOHNSON

MAXITORQ®

**MODEL MMS / MMD / MOR
MECHANICAL MULTIPLE DISC
CLUTCH**



**MAINTENANCE
REPAIR
TROUBLESHOOTING
MANUAL**

*The Carlyle Johnson Machine Company, LLC
291 Boston Turnpike / P O Box 9546 / Bolton, Connecticut 06043
(860) 643/1531 / Toll Free (888) - MAXITORQ
www.cjmco.com*



SAFETY WARNING

**ALWAYS DISCONNECT POWER AND AIR
AND LOCK OUT / TAG OUT MACHINE
BEFORE PERFORMING SERVICE
OR REMOVING/INSTALLING CLUTCH**

**WHERE ON-MACHINE ADJUSTMENTS
ARE REQUIRED,
MACHINE MUST BE IN A SAFE CONDITION
WITH POWER AND AIR DISCONNECTED
AND NO STORED ENERGY PRESENT.**

**USE PROPER SAFETY EQUIPMENT
INCLUDING EYE PROTECTION
WHEN REMOVING/INSTALLING
OR PERFORMING MAINTENANCE
ON CLUTCH**

CONTENTS

Safety Warning	Inside Cover
Contents	1
Section View	2
Exploded Parts Diagram	3
Routine Maintenance	
Preventive Maintenance	4
Replacement of Clutch Discs and Springs	4
Wear Items	4
Adjustments	
Notes on Clutch Adjustment	5
Adjusting Model <u>MMS/MMD</u> Clutches	
Adjusting Clutches Equipped with Standard Levers	6
Model MMS/MMD Torque Rating Chart (Table 1)	6
Adjusting Clutches Equipped with Non-Locking Levers	7
Adjusting Clutches Equipped with Locking-Style Levers	7
Adjusting Model <u>MOR</u> Clutches	8
Troubleshooting	
General Troubleshooting	9
Clutch fails to engage - no torque transmitted	10
Clutch slips - only partial torque transmitted	10
Clutch fails to disengage	11
“Neutral Drag” - Clutch transmits torque when disengaged	11
Maintenance Procedures	
Alignment	12
Drive Cup Engagement	12
Yoke Assembly	12
Drive Cup to Adjusting Ring Clearance	12
Secure Installation	13
Disc Contamination	13
Drive Cup wear	13
Disc wear	13
Separator Springs	14
Contacting the Factory	14
Clutch Disassembly	15
Recommended Lubricants (Table 2)	15
Clutch Assembly	16
Disc Complement Chart (Table 3)	16

SECTION VIEW

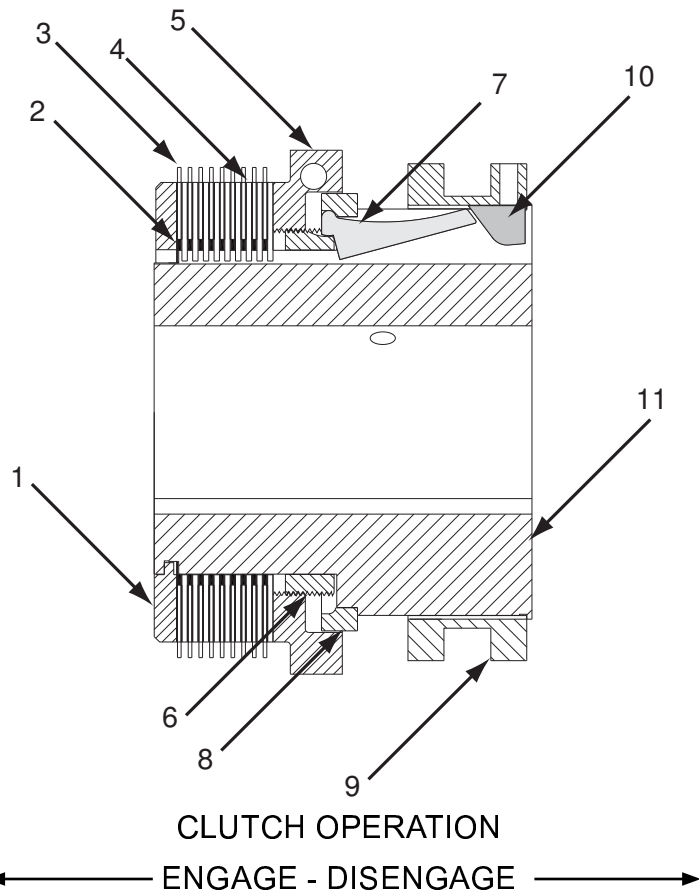

- 1 Locking Plate
- 2 Separator Spring
- 3 Outer Disc
- 4 Inner Disc
- 5 Adjusting Ring (with Set Screw)
- 6 Thrust Collar
- 7 Lever
- 8 Lever Retaining Ring
- 9 Sleeve
- 10 Wedge
- 11 Body (with Set Screw) (Single or Double, as applicable)

EXPLODED PARTS DIAGRAM

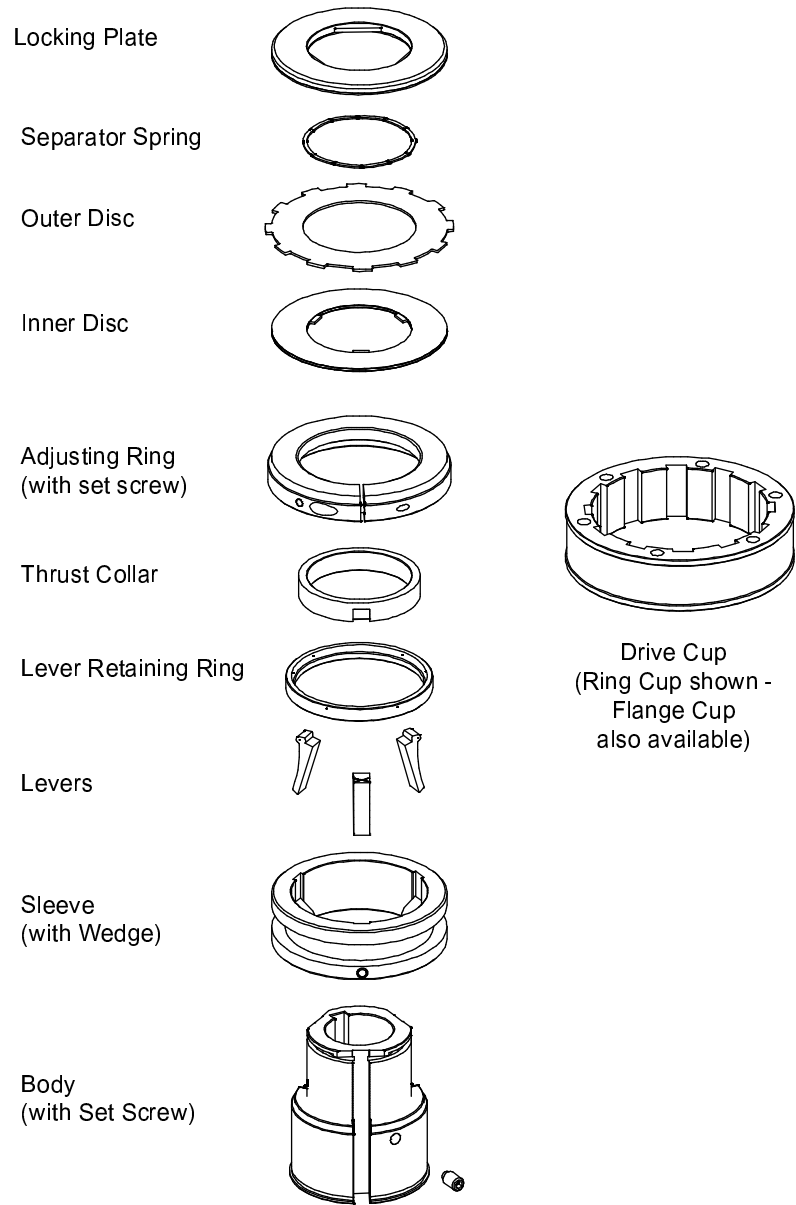

Model MMS shown - other models similar

ROUTINE MAINTENANCE

Preventive Maintenance

MAXITORQ® Multiple Disc Clutches need little or no maintenance in normal use. Discs on clutches may be washed in kerosene to remove any foreign material and restore clutch performance.

When a clutch is operated in oil, the oil may eventually break down along the friction surfaces. Over time, the hardened surfaces will wear. Discs should be visually inspected from time to time, to make sure warping and galling have not occurred. If any such wear is evident, disc replacement is necessary.

Replacement of Clutch Discs and Springs

Always replace Discs and Springs as a set. Do not mix old and new Discs on a Clutch. Always replace both Outer and Inner Discs at the same time.

Although Springs may be reused if they are still serviceable, frequently they lose their hardness and clutch performance - particularly disengagement and "neutral drag" becomes a problem. We recommend purchasing and installing a complete Disc/Spring set to restore like-new performance.

Wear Items

During routine inspection, check for areas within the Clutch which are subject to wear over time. Levers, Wedges, as well as Discs and Springs will need replacement after extended service. The factory can supply new parts or repair your clutch to restore its performance.

Check the surfaces of the Drive Cup where it contacts the tabs on the Outer Discs. Over time, even slight misalignment of the Clutch and Cup may result in "grooves" being worn into the Drive Cup, preventing reliable engagement or disengagement. If any such wear is evident, the Drive Cup must be replaced.

Clean the Clutch by flushing it with kerosene. The entire assembly may be immersed for cleaning. More thorough cleaning of the Discs and Springs can be accomplished by removing them from the Clutch as noted above.

Using compressed air, blow out any residue or contamination from the Shifter area of the Clutch, as well as the Disc/Spring area. Make sure the Clutch is dry before reinstallation, particularly if it is an oil-bathed application. Lubricate the Clutch as outlined in [Table 2](#) before installation in a dry application.

Check for smooth engagement/disengagement to determine if Wedges or Levers need replacement.

ADJUSTMENTS

Notes on Clutch Adjustment

MAXITORQ® Mechanical Clutches and Overload Release Clutches are shipped from the factory with all adjustments set for installation and use.

In normal use, Clutch adjustment should not be required. However after extensive use, or following Disc/Spring replacement in the field, it may be necessary to adjust the clearance between the Adjusting Ring and the adjacent Inner Disc.



WARNING! THIS ADJUSTMENT SHOULD BE PERFORMED WITH THE CLUTCH ON A WORKBENCH. DO NOT PERFORM PRELIMINARY ADJUSTMENTS WHILE THE CLUTCH IS INSTALLED ON A SHAFT!

Proper adjustment of the Adjusting Ring on the Clutch will allow the Clutch to engage and disengage fully when it is installed.

Insufficient Adjustment (with the ring too loose) may prevent full engagement, allowing the Clutch to slip. Excessive heat buildup will damage the Clutch and require premature Disc replacement. The Clutch will not give satisfactory service if it is not properly adjusted.

Excessive Adjustment (with the ring too tight) may prevent full disengagement, which is a safety hazard. In addition, excessive adjustment may prevent the Levers from having sufficient travel to lock in the engaged position, preventing full Clutch engagement and damaging the Clutch.



**DO NOT PLACE A CLUTCH INTO SERVICE
PRIOR TO VERIFYING PROPER ADJUSTMENT.**

**A CLUTCH WHICH IS IMPROPERLY ADJUSTED
IS A SAFETY HAZARD
AND CAN CAUSE SERIOUS INJURY TO PERSONNEL
AS WELL AS EQUIPMENT DAMAGE!**

ADJUSTING MODEL MMS/MMD CLUTCHES

Adjusting Clutches Equipped with Standard Levers

- 1 Place the Clutch on a workbench with the Locking Plate facing UP.
- 2 Using a hex wrench, loosen the set screw on the Adjusting Ring.
- 3 Turn the Adjusting Ring until it contacts the adjacent Inner Disc.
- 4 Continue turning the Adjusting Ring by hand until it is firmly seated against the Discs. **DO NOT FORCE** the ring or overtighten it.
- 5 Turn the Clutch over and press down on the Sleeve. The Clutch should engage and the sleeve should stay in the engaged position. Turn the Adjusting Ring as required until this condition is met. The Adjusting Ring must not be so loose that it does not firmly contact the Discs.
- 6 When the above conditions are achieved, tighten the Set Screw on the Adjusting Ring and again invert the clutch, and check its engagement. Frequently, an additional slight adjustment may be needed as tightening the Set Screw changes the relationship of the Adjusting Ring and the Discs.
- 7 When properly adjusted, the sliding Shifter sleeve requires a distinct pressure, or “snap” for full engagement.
- 8 If the Clutch shifts into full engagement with little or no axial pressure, it is under adjusted, and will slip when loaded. If very high pressure is required, the Clutch will not completely engage except by applying excess pressure. This will prevent the Clutch Discs from separating, preventing full disengagement.
- 9 Verify the settings using the values in Table 1, below, OR to a value specified by the Equipment Manufacturer.

Model MMS/MMD Torque Rating Chart			
(for clutches using standard levers)			
Clutch Model (MMS / MMD)	Shifting Force (LBS)	Clutch Model (MMS / MMD)	Shifting Force (LBS)
20	15	25	60
21	20	26	80
22	30	27	105
23	30	28	150
24	40		

Axial Shifting Sleeve Force (in LBS) required to attain full engagement of
Mode MMS/MMD Mechanical Clutches and handle rated torque
(when equipped with standard Levers)

Table 1

ADJUSTING MODEL MMS/MMD CLUTCHES

Adjusting Clutches Equipped with Non-Locking Levers

- 1 Place the Clutch on a workbench with the Locking Plate facing UP.
- 2 Using a hex wrench, loosen the set screw on the Adjusting Ring.
- 3 Turn the Adjusting Ring until it contacts the adjacent Inner Disc.
- 4 Continue turning the Adjusting Ring by hand until it is firmly seated against the Discs. DO NOT FORCE the ring or overtighten it.
- 5 When the above conditions are achieved, tighten the Set Screw on the Adjusting Ring.
- 6 The Non-Locking Levers are designed to allow the clutch to be held in the engaged position by the force applied to the Shifter. Rapid engagement and disengagement is possible in applications where intermittent action is required. In a Brake application, the braking action is proportional to the Shifter force, since the Shifter Sleeve never locks itself.
- 7 After completing the above rough adjustment, check the Clutch behavior when installed. Frequently, an additional slight adjustment may be needed as tightening the Set Screw changes the relationship of the Adjusting Ring and the Discs.

Adjusting Clutches Equipped with Locking Style Levers

- 1 Locking Levers are often used in machinery that is subjected to exceptional levels of vibration. The engagement force for such Clutches can be set using the same procedure outlined under "Adjusting Clutches Equipped with Standard Levers".
- 2 Table 1 values for engagement force are used for Locking Style Levers.
- 3 Disengagement force required is approximately TWICE that of Clutches equipped with Standard Levers.
- 4 Always adjust the Clutch to achieve the proper engagement force. The disengagement force is controlled by the design of the Levers, and should NOT be adjusted.

ADJUSTING MODEL MOR CLUTCHES



MAKE SURE ALL DISC SURFACES ARE CLEAN BEFORE ATTEMPTING ADJUSTMENT OF OVERLOAD RELEASE CLUTCHES

- 1 Place the Clutch on a workbench with the Locking Plate facing UP.
- 2 Using a hex wrench, loosen the set screw on the Adjusting Ring.
- 3 Turn the Adjusting Ring until it contacts the adjacent Inner Disc.
- 4 Continue turning the Adjusting Ring by hand until it is lightly seated against the Discs. **DO NOT TIGHTEN THE RING AT THIS TIME!**
- 5 Turn the Clutch over and press down on the Sleeve. The Clutch should engage very easily and the Sleeve should stay in the engaged position. Turn the Adjustment Ring if necessary, until this condition is met. **NOTE:** The Adjusting Ring should not be so loose when disengaged that it does not lightly contact the Discs.
- 6 When the above conditions are achieved, tighten the Set Screw on the Adjusting Ring and again invert the Clutch and check its engagement. Frequently, an additional slight adjustment may be needed as tightening the Set Screw changes the relationship of the Adjusting Ring and the Discs.



WARNING! The following steps require installation and operation of the Model MOR Overload Release Clutch on the equipment. When on-machine adjustments are required, **POWER AND AIR MUST BE DISCONNECTED!**

- 7 Install the Clutch and tighten the Set Screw in the Body. Apply power to the Clutch. Because it was previously adjusted to a very light engagement position, the Clutch should immediately throw out. IF IT DOES NOT, LOOSEN THE SET SCREW ON THE ADJUSTING RING AND BACK THE RING OFF 10° AT A TIME UNTIL THIS SETTING IS ACHIEVED. It is best to start the final on-machine adjustment process from a very light disengagement setting.
- 8 Remove the power and air from the machine. Loosen the Set Screw on the Adjusting Ring and rotate the ring to increase (or decrease - as appropriate) the holding power of the Clutch. Do not turn the ring more than 10° at a time in either direction before tightening the Set Screw and rechecking the setting.
- 9 After each adjustment, apply power to the Clutch, until it is just able to hold the required torque. DO NOT OVER ADJUST THE CLUTCH! If the clutch is over adjusted, too much torque will be required before overload occurs, creating a dangerous condition.
- 10 When setting the Clutch for very light loads, more careful adjustments must be made - using 5° increments or less.

TROUBLESHOOTING

General Troubleshooting

- 1 Check for worn parts. Obviously worn or damaged parts must be replaced to insure correct Clutch operation. Determine whether this wear is due to normal operation over a long period of use, or improper installation, maintenance, assembly, or clutch contamination.

Replacing worn parts will provide only temporary improvement in Clutch operation, if a more fundamental problem is present and goes undetected.
- 2 Check alignment of Clutch and Drive Cup. Review the paragraph on "Alignment". Improper alignment will asymmetrically load the Clutch and Drive Cup, causing premature wear and possibly interfering with Clutch operation.
- 3 Check for contamination of Clutch Discs. Discs in dry applications may become contaminated with oils from adjacent bearings or other external sources, which will prevent the Clutch from transmitting full torque. Slippage is frequently caused by such contamination. Clean the Discs as outlined under "Contamination".
- 4 Check clearances. Check that the relationship of the Drive Cup to the Adjusting Ring meets specifications as outlined under "Alignment". Also verify that when the Clutch is disengaged, it will rotate freely with no binding or interference.
- 5 Check for missing or damaged parts. If the Clutch has been subjected to removal, repair, and reinstallation, check to see if the Clutch has been reassembled correctly. Review the parts diagram included in this manual and replace or repair any damaged or missing parts.
- 6 Check engagement and disengagement. It may be necessary to adjust the Clutch if it does not fully engage and fully disengage. Any slippage when engaged, or continuing torque transmission when disengaged, indicates the need for adjustment. Review the sections on "Adjustment" for instructions.



**WORN OR MISALIGNED PARTS
CREATE A SAFETY HAZARD
AND CAN CAUSE SERIOUS INJURY TO PERSONNEL
AS WELL AS EQUIPMENT DAMAGE!**

TROUBLESHOOTING, con't

Clutch Fails to Engage - No Torque Transmitted

Check the following with the clutch installed (see **SAFETY WARNING** inside front cover)

- 1 Alignment
- 2 Drive Cup engagement
- 3 Yoke assembly
- 4 Drive Cup to Adjusting Ring clearance
- 5 Secure Installation

Remove the Clutch and check the following:

- 6 Disc contamination
- 7 Drive Cup wear
- 8 Disc wear

Clutch Slips - Only Partial Torque Transmitted

Check the following with the clutch installed (see **SAFETY WARNING** inside front cover)

- 1 Alignment
- 2 Secure Installation

Remove the Clutch and check the following:

- 3 Disc contamination
- 4 Drive Cup wear
- 5 Disc wear
- 6 Separator Springs

TROUBLESHOOTING, con't

Clutch Fails to Disengage



WARNING! DO NOT OPERATE EQUIPMENT IF CLUTCH FAILS TO PROPERLY DISENGAGE. REPAIR OR REPLACE CLUTCH BEFORE CONTINUING OPERATION

Check the following with the clutch installed (see **SAFETY WARNING** inside front cover)

- 1 Alignment
- 2 Yoke assembly
- 3 Drive Cup to Adjusting Ring clearance
- 4 Secure Installation

Remove the Clutch and check the following:

- 5 Disc contamination
- 6 Drive Cup wear

“Neutral Drag” - Clutch Transmits Torque when Disengaged



WARNING! DO NOT OPERATE EQUIPMENT IF CLUTCH FAILS TO PROPERLY DISENGAGE. REPAIR OR REPLACE CLUTCH BEFORE CONTINUING OPERATION

Check the following with the clutch installed (see **SAFETY WARNING** inside front cover)

- 1 Alignment
- 2 Drive Cup to Adjusting Ring clearance
- 3 Secure Installation

Remove the Clutch and check the following:

- 4 Disc contamination
- 5 Drive Cup wear
- 6 Separator Springs

MAINTENANCE/REPAIR PROCEDURES

Alignment

The Clutch and Drive Cup must be concentric within .005 T.I.R. Misalignment may be caused by improper Clutch mounting; improper mounting or support of the Drive Cup; or worn bearing supporting the Drive Cup.

Clearance between the Drive Cup fingers and the Adjusting Ring must be approximately 1/16". Measure this dimension around the entire circumference of the Drive Cup; it must be uniform.

If the 1/16" is not maintained around the entire circumference, it is an indication of Clutch to Cup misalignment, and must be corrected.

Drive Cup Engagement

The Drive Cup must engage all of the Outer Discs. Adjust the alignment of the Drive Cup if necessary, or repair/replace external components or Clutch mounting to correct any deficiency.

Inspect carefully the area where the Drive Cup contacts the Outer Discs. Make sure the tabs on the last Outer Disc are fully contained in the Drive Cup, and that the last Outer Disc is not "pinched" anywhere on its circumference.

Prolonged use with a misaligned Drive Cup can result in "grooves" being worn into the cup. The Outer Discs will then tend to seat themselves in these grooves and fail to properly engage or disengage. If this condition is observed, Drive Cup replacement is necessary.

Yoke Assembly

The Shifter Yoke Assembly normally is attached to the Clutch through the Shifter Shoes, which are attached to the Sleeve with Studs. The yoke assembly must have sufficient travel range to engage and disengage the Clutch. Any binding or restriction must be addressed to insure smooth Clutch action.

Shifter Shoes are attached with factory-installed Studs. Worn Shoes must be replaced. The factory can supply parts for field replacement, but in-factory repair is recommended.

Drive Cup to Adjusting Ring Clearance

Clearance between the Drive Cup and Adjusting Rings must be approximately 1/16". This dimension must be uniform around the entire circumference of the Drive Cup. See the section "Alignment", above.

MAINTENANCE/REPAIR PROCEDURES, con't

Secure Installation

The Clutch must be secured to a shaft with a key, and locked in place with the Body Set Screw. Check that the installation is secure and that the Clutch is not able to move when installed.

Disc Contamination

Contamination of Discs in Clutches run dry can be caused by oils from external sources, or other debris. Discs may be flushed with kerosene to remove oils or other contaminants, and restore normal performance. Air dry discs after flushing.

Bearings in the vicinity of the Clutch - for example used to support the Drive Cup - should be adequately shielded to prevent Disc contamination.

Clutches run in oil must not use oil containing extreme pressure additives. We recommend ATF oils such as Dexron II® for this application.

Drive Cup Wear

Improper alignment, support, worn bearings, or extreme service may eventually wear "grooves" into the fingers of the Drive Cup. The Outer Discs will then tend to seat themselves in these grooves and fail to properly engage or disengage. If this condition is observed, Drive Cup replacement is necessary.

When replacing the Drive Cup, any supporting bearings or alignment issues must be corrected or the condition will be repeated.

Check Discs carefully if there is wear evidence on the Outer Disc tabs. Discs may have been damaged and replacement may be necessary.

Disc Wear

After extended use, the Clutch Discs will wear to a point where replacement is necessary. In a dry application, if normal operation cannot be restored to a slipping clutch with kerosene flushing, then Disc replacement is required.

In oil-bathed applications, oil will eventually break down along the friction surfaces. Over time, the hardened surfaces can become worn to a point where warping or galling occurs. This damage can be clearly seen by checking the disc surfaces, and requires prompt Disc replacement to maintain good Clutch performance.

Always replace Discs and Springs as a set. The factory can supply Disc/Spring kits for field replacement. Repair service at the factory is also available.

MAINTENANCE/REPAIR PROCEDURES, con't

Separator Springs

If the Clutch transmits excess torque when in neutral (disengaged), Separator Springs may be worn or bent. Springs should be replaced under these circumstances.

Proper Spring performance is achieved when the Discs are uniformly spaced while in the disengaged position.

Contact the factory to purchase replacement Springs. Normal, if Springs have reached this point, it is a good idea to replace the friction Discs at the same time, to restore the Clutch to like-new performance.

Contacting the Factory

MAXITORQ[®] Clutches and Brakes are manufactured by The Carlyle Johnson Machine Company, LLC (Cage Code 75182). Contact information is shown on the cover of this manual.

Spare parts may be ordered by calling the factory. Always provide Model and Serial Number when ordering parts.

Additional copies of this manual are available free of charge.

Before returning a Clutch or Brake for service, call for an RMA number. This will speed the handling of your *MAXITORQ*[®] product. Always give the technician the Model and Serial number of the device being returned.

Upon receipt, your Clutch or Brake will be evaluated, and a report will be furnished to you showing cost and schedule for overhaul/maintenance. If you direct us to return the unit without repair, an evaluation charge may apply.

Carlyle Johnson is located in the Eastern Time Zone of the United States and can be reached between 8:00 AM and 5:00 PM Monday - Friday, excluding U.S. legal holidays.



**ALWAYS USE PROPER SAFETY EQUIPMENT
INCLUDING APPROVED EYE PROTECTION
WHEN INSTALLING, REMOVING,
OR SERVICING CLUTCH**

CLUTCH DISASSEMBLY

- 1 Place the Clutch on a workbench with the Locking Plate facing UP.
- 2 Using a hex wrench, loosen the set screw on the Adjusting Ring.
- 3 Turn the Adjusting Ring away from the Discs until it is free of any contact with the Discs.
- 4 Remove the Locking Plate by pressing down and rotating it 60°. This will free the bayonet lock and allow the Locking Plate to be removed.
5. Remove the Outer Discs, Separator Springs, and Inner Discs from the Body. If you are only replacing Discs and Springs, no further disassembly is necessary.
- 6 Remove the Adjusting Ring and Levers.
- 7 Remove the Lever Retaining Ring, Sleeve, and Thrust Collar.
- 8 Thoroughly clean all parts before reassembly.
- 9 Discs, Springs, and Levers are easily replaced when worn and unserviceable. Although Wedges and Shifter Shoes can be purchased from the factory, field replacement is not recommended. Return the Clutch to the factory for proper replacement of these parts.

Mechanical Clutch Recommended Lubricants	
Contact Points	Lubricant
Shifter Sleeve : Body	Light Oil (#10 or #20)
Shifter Shoes : Shifter Sleeve	Grease such as "Lubriplate"
Lever Ends : Wedges	Light Oil (#10 or #20)
Lever Ends : Retaining Ring	Light Oil (#10 or #20)
Discs	Flush with Kerosene, Air Dry

Table 2

CLUTCH ASSEMBLY

- 1 Place the Body on a workbench with the small diameter end facing UP.
- 2 Place the Thrust Collar on the Body with the three milled slots facing DOWN. Align the slots with the milled slots on the Body.
- 3 Insert a Lever into each milled slot on the Body, with the flat side of the Lever facing the Body.
- 4 Place the Lever Retaining Ring over the Body.
- 5 Raise the Thrust Collar and Levers UP until the round heads of the Levers are in the circular recesses of the Lever Retaining Ring.
- 6 Screw on the Adjusting Ring until the face of the ring is flush with the face of the Thrust Collar.
- 7 Select an Inner Disc. Inner Discs have internal lugs to fit into the milled slots on the Body. Slide an Inner Disc on the Body.
- 8 Place a Separator Spring over the Body, so it rests on the Inner Disc previously installed.
- 9 Select an Outer Disc. Outer Discs have external lugs to fit into the slots of the Drive Cup. Slide the Outer Disc on the Body.
- 10 Continue installing Inner Discs, Separator Springs, and Outer Discs until the proper number of each are on the Body. The last disc to be installed will be an Outer Disc. [Table 3](#) below shows the number of Discs by Clutch model.
- 11 Place the Locking Plate over the Body. Press down and rotate the Locking Plate approximately 60° until the Locking Plate snaps into position and is locked. If the plate cannot be locked, check to be sure the Separator Springs are not causing a restriction (and that they fit within the I.D. of the Outer Discs), or that the Levers have not fallen out of position.
- 12 The Clutch should turn freely without any restriction or interference. The Sleeve should move freely engaging and disengaging the Clutch (although the engagement force is inadequate in this position, and proper adjustment is required before installation).
- 13 Proper lubrication is required before installation. See [Table 2](#) for this information.

Model MMS/MMD Disc Complement Chart			
<small>(Inner discs, Outer discs, and Springs are EACH used in quantity shown)</small>			
Clutch Model (MMS / MMD)	Discs/Springs (QTY)*	Clutch Model (MMS / MMD)	Discs/Springs (QTY)*
20	5	25	6
21	5	26	7
22	5	27	8
23	6	28	9
24	6		

Table 3

NOTES



*The Carlyle Johnson Machine Company, LLC
291 Boston Turnpike / P O Box 9546 / Bolton, Connecticut 06043
(860) 643/1531 / Toll Free (888) - MAXITORQ
www.cjmco.com*